



***AcE-Bs2021KotaBharu***  
<https://www.amerabra.org>; <https://fspu.uitm.edu.my/cebs>; <https://www.emasemasresources.com/>  
**9<sup>th</sup> Asian Conference on Environment-Behaviour Studies**  
Perdana Kota Bharu, Kelantan, Malaysia, 28-29 Jul 2021



## Eco-Business Initiatives Among Malaysian SME Green Technology Companies

**Siti Zahrah Buyong, Sharifah Zannierah Syed Marzuki,  
Junainah Junid, Mohd Ali Bahari Abdul Kadir**

Faculty of Business and Management,  
Universiti Teknologi MARA, Puncak Alam, Selangor Darul Ehsan, Malaysia.

[siti280@uitm.edu.my](mailto:siti280@uitm.edu.my), [szannierah@uitm.edu.my](mailto:szannierah@uitm.edu.my), [junainahjunid@uitm.edu.my](mailto:junainahjunid@uitm.edu.my), [mohda419@uitm.edu.my](mailto:mohda419@uitm.edu.my)  
Tel: +603-3258 7042

### Abstract

Environmental problems are becoming more prevalent not only in Malaysia but globally as well. The most serious issue that has been posted is the lack of explicit environmental protection capabilities. According to the results of this study, regulations, consumer pressure, and social responsibility have a significant association with planned market benefits. Thus, have a wide-ranging effect, as they serve as a critical component in facilitating the company operating system's adoption of green practices. The country is heading to be a technologically advanced economy from material production to manufacturing while ensuring that sustainability is achieved.

Keywords: eco-business; Malaysian; SME; green

*eISSN: 2398-4287© 2021. The Authors. Published for AMER ABRA cE-Bs by e-International Publishing House, Ltd., UK. This is an open access article under the CC BYNC-ND license (<http://creativecommons.org/licenses/by-nc-nd/4.0/>). Peer-review under responsibility of AMER (Association of Malaysian Environment-Behaviour Researchers), ABRA (Association of Behavioural Researchers on Asians/Africans/Arabians) and cE-Bs (Centre for Environment-Behaviour Studies), Faculty of Architecture, Planning & Surveying, Universiti Teknologi MARA, Malaysia.  
DOI: <https://doi.org/10.21834/ebpj.v6i17.2827>*

### 1.0 Introduction

Environmental issues have become a big challenge and are being discussed seriously worldwide (Eltayeb, Zailani & Ramayah, 2011). Developing countries are beginning to be sensitive to this issue when looking at the many benefits from implementing environmental care that encompasses all aspects of life, including doing business that should positively impact entrepreneurs. Besides, the world today is surrounded by various types of technology used in the business environment. The issue of environmental destruction caused by the misuse of technology is another factor becoming more prevalent in all parts of the world. This problem is evidenced by various incidents where the destruction of nature is due to human actions worldwide that impact life on earth, especially humans, animals, plants, and others.

Nevertheless, environmental management and issues are least discussed among Small and Medium Enterprises (SMEs) (Lin, Shah Alam, Ho, Al-Shaikh & Sultan, 2020) even though SMEs are well known for playing an important role in a country's economic development and are considered as the backbone of economic growth in any country. In Malaysia, a business is categorized as an SME if it maintains revenues, assets, or some employees below a certain threshold. Table 1 gives the definitions of SMEs in Malaysia based on their size of operation and sector.

*eISSN: 2398-4287© 2021. The Authors. Published for AMER ABRA cE-Bs by e-International Publishing House, Ltd., UK. This is an open access article under the CC BYNC-ND license (<http://creativecommons.org/licenses/by-nc-nd/4.0/>). Peer-review under responsibility of AMER (Association of Malaysian Environment-Behaviour Researchers), ABRA (Association of Behavioural Researchers on Asians/Africans/Arabians) and cE-Bs (Centre for Environment-Behaviour Studies), Faculty of Architecture, Planning & Surveying, Universiti Teknologi MARA, Malaysia.  
DOI: <https://doi.org/10.21834/ebpj.v6i17.2827>*

Table 1: Definition of SMEs Based on Its Size of Operations and Sector

Category	Small	Medium
Manufacturing	Sales turnover from RM300,000 to less than RM15 million OR full-time employees from 5 to less than 75.	Sales turnover from RM15 million to not exceeding RM50 million OR full-time employees from 75 to not exceeding 200.
Services & Other Sectors	Sales turnover from RM300,000 to less than RM3 million OR full-time employees from 5 to less than 30.	Sales turnover from RM3 million to not exceeding RM20 million OR full-time employees from 30 to not exceeding 75.

Source: *SME Corporation Malaysia, (2014)*

SMEs play a critical role in Malaysia's economy. The SME sector contributes to over five million workers and RM500 million in the gross domestic product (GDP). However, this contribution of SMEs to the economy comes at the expense of increase environmental footprint (Koirala, 2018). As a result, numerous stimulus packages proposed for SMEs, including those relating to the sustainability of an environmentally sustainable climate, the government fully supports this sector's positive progress. This positive aspect can be seen in implementing the eco-business model, where various studies are proven either through quantitative or qualitative methods that show significant results to the business (Eltayeb et al., 2011; Lehtoranta, Nissinen, Mattila & Melanen, 2011). The involvement of various parties more comprehensively can contribute to the sustainability of the environment in this country.

### 1.1 Introduction to Environmental Issues in Malaysia

As one of the developing countries, Malaysia also sees this as an important issue where various problems are also highlighted. Countless communication between the industrial players is continuously being held. The topic that is consistently discussed regarding environmental issues among businesses is environmental management that is faced in Malaysia but around the globe. This is a challenging problem not only for the regulators, administrators but also the business itself. Previous research links business operations as a significant source of increasing pressure in dealing with this issue, including air pollution related to air discharge from companies, dumping of business waste into rivers which is a source of water causing environmental degradation from time to time.

When sustainability is thoughtfully incorporated into corporate practices, research reveals that it provides business advantages. Previous researchers have repeated several times in their study where the leading cause of all these problems is unethical business operations, which cause air pollution, water pollution, environmental degradation, and drainage (Eltayeb et al., 2011). Society today is increasingly concerned with the state of the environment affected every day they want a greener environment with a healthier and environmentally friendly lifestyle. Therefore, this research aims to investigate what drives the SMEs to have eco-business initiatives in running the business and managing environmental issues thus benefiting the SMEs themselves whilst making a positive impact on the environment.

## 2.0 Literature Review

### 2.1 Key Drivers

Green initiatives have been adopted by many public listed companies in various areas such as waste management, green packaging, corporate environmental management, green strategies, and green marketing (Abdul Aziz et al., 2018). Nevertheless, the concept of green practices in business operations can be said to be still in the early stages among Malaysian SME owners/entrepreneurs, and very few empirical studies for the SMEs in the South East Asia region (Lin et al., 2020). The government, through various initiatives, has held seminars, conferences, courses, workshops in implementing green campaigns among SME entrepreneurs in the hope of providing awareness at an early stage about the importance of the environment.

Ensuring the implementation of the eco-business model in any country requires a key driver in moving this initiative. The main drivers that should move are from the government itself in introducing its regulations and enforcement on SMEs' green practice (Wooi & Zailani, 2010; Yahya et al., 2014). Within this context, customer pressure, business benefits, and social responsibility (Yusoff & Adamu, 2016) from the community itself. Studies show that the results of the green initiative introduced are directly related to environmental conditions, cost reduction, economy, and building the company's image, reputation, and brand. Worthington and Patton (2005) have suggested that special research should be given to SME entrepreneurs to assist them in shaping healthy environmental behaviors. SMEs should adopt environmental initiatives because this effort can reduce the poor environmental performance as a result of negative attitudes by entrepreneurs or SME managers.

De Bruijn and Lulofs (2001) have identified five key drivers of environmental management practices that by SMEs as green practices. Economic benefits, financial rewards, stakeholder desire, policy, money, inspiration, and awareness are the five main drivers that have been developed in Malaysia (Moorthy et al., 2012). According to them, adopting this driver in the business context will produce positive results. In ensuring the effectiveness of this effort, the key drivers identified should bring benefits to SMEs.

#### 2.1.1 Regulation

Organizations or companies were enforcing their incentives through eco-design in reflects of environmental regulations. Ravi, Shankar, and Tiwari (2005) highlighted that the rules and incentives include formal rules, laws, sanctions, and incentives. The incorporation of environmental legislation levied by the government and other governmental bodies on organizations to enforce evident sustainability practices is explained as a driver towards green initiatives (Bansal & Roth, 2000). European countries have shown their concern by strictly

controlling forbid products and applying recycling items (Webster & Mitra, 2007). Ramli and Munisamy (2013) supported those industrial countries are very concerned about global environmental sustainability in recent years. However, the issues of pollution and production activities are being discussed worldwide.

Malaysia has depended on agriculture for the past three decades and now focusing on industrial sectors. The country needs to shift to a greener economy to sustain economic and environmental criteria, thus achieving environmental sustainability. This should be based on environmental regulations that appear to be significant. The role of regulation concerning a firm's competitiveness ensures that sustainability is achieved and improves economic, social, and environmental performance. Companies must receive support from the government and regulatory bodies to meet their efficiency and reliability objectives to be competitive in terms of green practices.

### **2.1.2 Customer Pressure**

Businesses must maintain a clear competition focus, emphasizing the importance of valuing consumers to gain a strategic edge. When it comes to deciding whether to start with a green initiative when manufacturing goods or services, customer pressure is significant (Yu, Hills & Welford, 2008). Customers are becoming increasingly conscious of the importance of green practices. The awareness among customers towards green practices is growing at an increasing rate. Thus, the pressure from there is inevitable. Customers' pressure and demands for green goods are being applied to Asian countries in this way, as most developing countries, such as Japan, the United States, and European countries, import parts or products from them. According to Anbumozhi and Kanda (2005), customer demand is the most powerful force in ensuring that businesses are serious about eco-initiatives.

Amongst Malaysian companies, environmental sustainability has recently gained attention from industry players and scholars. The local companies realize that green initiatives have an impact on environmental sustainability. However, such practice is still in its infancy (Savita, Dominic & Ramayah, 2012). Several demands on manufacturing companies to adopt eco-friendly products are becoming alarmingly strong, as consumers consider greening the products necessary. For all these reasons, companies should adopt green initiatives to achieve environmental compliance improvement, enhance environmental performance and create a better financial performance. In essence, this will lead to expected business benefits that make business sustainability.

### **2.1.3 Corporate Social Responsibility**

Corporate Social Responsibility (CSR) is gaining popularity and has become an essential element to many corporations. In recent years, businesses began to implement their very own CSR initiatives. In some cases, they voluntarily offer reports of the CSR initiatives (Christensen et al., 2019) to know their involvement in socially responsible activities. Participation in CSR allows businesses to set themselves apart from rivals by exploiting their company's brand compared to others, resulting in reputational gains.

People constantly relate CSR to community engagement, philanthropic contributions, good corporate governance, enforcement of "green" policies, and a wide range of other organizational activities (Crane et al., 2008). This multifaceted nature of CSR led to continuous pressure on business executives to adopt various strategies such as eco-innovation, eco-business model, and green management practices to contribute to environmental sustainability. This may include restructuring the departments and revisiting existing conventional business models to demonstrate the integration of a more sustainable and eco-friendly business model.

### **2.1.4 Expected Business Benefits**

Practicing the eco-business model should be holistic which Business-to-Business (B2B), and Business-to-Consumer (B2C) businesses are also included. In the establishment of sustainable development, eco-innovation is essential. It would generate positive changes not only in SMEs but also in their environment. Policymakers, scholars, and the corporate world are gradually seeing the need to transition to a modern eco-business paradigm that can have many advantages, such as reintroducing goods and resources from recycled items or by-products into the economic system (Ellen MacArthur Foundation, 2015). The Advantages of Using an Eco-Business Model for SMEs are as below:

#### **i. Improving Environmental Performance**

Being environmentally conscious protects the atmosphere by reducing toxins in the soil, water, and air. Alternative energy options that attempt to stop burning fossil fuels and waste recovery will also help to minimize waste. Halila (2011) explained that eco-innovation is an innovation that contributes to a sustainable environment by developing ecological improvement. It entails creating, implementing, or testing new products, systems, procedures, operational, or administrative approaches for the business or the client.

#### **ii. Improving Resource Efficiency**

On the other hand, SMEs are becoming more mindful of the advantages of enhancing resource quality. According to the European Commission (2013), one of the critical motivations for European SMEs to implement an eco-business model in their organization is to save money on materials, gain a comparative edge, and enter new markets. Rizos (2016) found that SMEs' performance in moving to an eco-business model is determined by how well the following considerations are supported:

1. a company culture with a "green" mindset among employees and managers.
2. a local or regional network with other SMEs and supporting multipliers to enhance information sharing and awareness-raising.
3. the benefits of having a "green" business model.

#### **iii. Sustainable Society**

Stakeholders now expect businesses to uphold a high degree of environmental responsibility and play a more prominent role in the growing pattern in eco-innovation. Running an environmentally conscious company has become critical because "eco" has become the gateway to gaining a competitive edge in the marketplace. Reusing or recycling materials and resources are referred to as "use one more time."

Items that are reusable or recyclable, and energy, are often discarded (Kondoh et al., 2012). Ranging from paper and pallets to plastic and metal packaging, it will be recycled.

iv. **Creating New Market Opportunities**

Eco-based products, services, or processes that can create new business opportunities were popularly known as 'eco-innovation'. Good practice of eco-business model can attract new customers. It will not only bring in more buyers, open new markets, and increase economic value, but it will also have a positive effect on the climate (Fussler & James, 1996).

**2.1.5 Brands Benefit to Firm**

According to Andersen (2010), eco-innovation not only demonstrates the firm's sustainability policies but also supports the brand. The first advantage can take the form of a price premium on an innovative, environmentally friendly product, operation, or marketing promotion. The second advantage is that the firm's manufacturing costs will be reduced because recyclable and reusable materials will be less expensive. As a sustainable activity, eco-innovations refer to implementing a new green idea or improving a current one to make it more environmentally friendly (De Marchi, 2012).

Most SMEs agree that the workforce's mindset and commitment are critical in easing the transition to a circular economy model to ensure widespread participation in the "eco-business model." Circular economy ideas are relatively easy to follow for newly created start-up companies or emerging entrepreneurs, since their organizational culture evolves from the ground up, and can be better than modifying processes of traditional businesses (Rizos et al., 2016).

**3.0 Methodology**

Researchers collected the data through a quantitative survey. The aim was to answer the main question of the study of what drives SMEs to embark on eco-business initiatives via statistical findings, which later generalize the managerial practices within Malaysian SME companies. The owners of 14 accredited Greentech SMEs in a manufacturing sector listed by Malaysia External Trade Development Corporation (MATRADE) has responded to the survey. Due to this inadequate response, the number is considered very low, with the pandemic health problem as a contributing factor and the movement control order (MCO) imposed by the government as the limitation of the research. The original idea was to hand out the questionnaires to the respondents in person but changed to using Google Forms to distribute them electronically. Therefore, this study is treated as a pilot study of a much bigger sample size later. This research used Smart PLS 3.0 software to perform hypotheses checking and validating steps using partial least square structural equation modeling (PLS-SEM). This study aims to use convergent validity and discriminant analysis to determine the relationship between latent variables.

**4.0 Findings**

Table 2 shows a demographic profile where most companies are in the growth and expansion stage. 13 companies are less than 15 years of age (n=13, 92.9%), and one company is more than 15 years of age (n=1, 7.1%). Less than 100 workers (n=11, 78.6%) have the highest proportion of employees, while 100 to 250 employees (n=1, 7.1%) have the lowest. According to the data (n=11, 78.6%), the respondents make consumer goods, while the remaining (n=3, 21.4%) make industrial products. The majority of the businesses are classified as private limited partnerships (n=9, 64.3%), enterprises (n=3, 21.4%), and public listed companies (n=2, 14.3%). Companies who engage in eco partnerships are (n=4, 28.6%), while the others (n=10, 71.4%), even though do not participate in green associations, but will consider registering and getting involved.

Table 2: Demographic Profiling

Profile		Frequency	%
N=14			
Age of firm	Less than 15 years	13	92.9
	More than 15 years	1	7.1
Number of employees	Less than 100	11	78.6
	100-250 employees	1	7.1
	251-520 employees	2	14.3
Type of products	Consumer products	11	78.6
	Industrial products	3	21.4
Ownership status	Enterprise	3	21.4
	Private limited company	9	64.3
	Public limited company	2	14.3
Green associations participation	Yes	4	28.6
	No	10	71.4

**4.1 Reliability Analysis**

To test the goodness of measure, validity and reliability tests are essential. Internal consistency analysis (Cronbach's alpha) was used to ensure that each study element was reliable. The higher the internal consistency reliability, the closer the Cronbach's alpha value is to one (Sekaran, 2000). Cronbach's values for both dimensions exceeded the minimum of 0.6 and between 0.9, which fall under great value as seen in Table 3. Regulation is stated as 0.893, customer pressure is 0.923, social responsibility is 0.908, and finally, the expected business benefits is 0.933 as a result, the constructs' measurements are regarded as reliable.

Table 3: Reliability and Discriminant Analysis

	CR	AVE	1	2	3	$\alpha$
Customer Pressure	0.944	0.808				0.923
Expected Business Benefits	0.952	0.833	0.672			0.933
Regulations	0.896	0.813	0.133	0.261		0.893
Social Responsibility	0.928	0.72	0.483	0.538	0.305	0.908

**4.2 Measurement and Structural Model**

This study has found that each variable's outer loadings are good loadings; and were higher than the recommended level of 0.7 (Hair et al., 2011). It is shown in Table 3 that the outer loadings of each variable are good loadings. Furthermore, the latent construct's average variance was higher than the prescribed value of 0.5. As a result, the convergent validity of the metrics of all the variables/constructs in the table tended to be large. Since the values of both variables are less than 0.9, discriminant validity is generated.

The antecedents of rules, market pressure, and social responsibility of eco-business benefits explained a total of 60.2 percent of difference (R2) in expected business benefits, as seen in Figure 1. Planned market advantages are significantly affected by regulations ( $\beta = 0.278$ ). With path ( $\beta$ ) coefficients of 0.525 and 0.262, respectively, customer pressure and social responsibility significantly impact expected business benefits (Table 4).

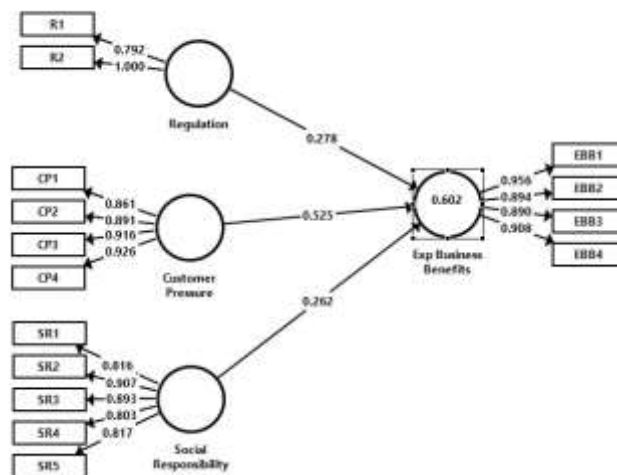

Figure 1: The Structural Model

Table 4: Total Effect

Factors	$\beta$
Regulations – Expected Business Benefits	0.278
Customer Pressure – Expected Business Benefits	0.525
Social Responsibility -Expected Business Benefits	0.262

**5.0 Discussion**

The research findings show that regulations, customer pressure, and corporate social responsibility are important factors to the expected business benefits of SMEs embarking on eco-business initiatives. This result is consistent with previous research that highlighted a policy as the most quoted catalyst for businesses to follow green practices (Zailani et al., 2015). Looking at developed countries such as the United States of America, it is clear that policies and legislation have increased environmental consciousness, resulting in the practice of environmental protection. Likewise, in China, stringent environmental regulations have been imposed to implement green initiatives that can influence the performance of the companies. Other drivers like customer pressure and social responsibility are significant in explaining the relationship with the expected business benefits.

The findings are also consistent with the local initiative undertaken by the Malaysian government to lower carbon footprint and reduce air pollution to upgrade the health of its society at large, thus creating a better and healthy environment (Fernando, Wah & Shaharudin, 2016). In addition, the government has created Malaysia's Green Technology Corporation to promote green technology to be at par with other initiatives exerted by most developing countries. The research findings are also consistent with a previous study that underlined the importance of businesses to have a sustainability standard in their everyday activities, being environmentally conscious and socially



responsible which proved to have a direct impact on a company's financial gains, improves the values of opportunity, creativity, and comparative advantage (Porter & Kramer, 2006).

## 6.0 Conclusion & Recommendations

This study underlines that regulations, customer pressure, and corporate social responsibility (CSR) as the factors that affect the expected business benefits of SMEs embarking on eco-business initiatives in Malaysia. These three elements may influence SMEs' future decisions of whether they will seriously involve in management practices that would elevate environmental consciousness and contribute to better environmental sustainability. Inevitably, environmental problems are becoming more prevalent in Malaysia, and achieving environmental consciousness while still achieving business growth is difficult. Looking at the atmosphere resulting from global and local environmental, it has been challenging in recent years. Sourcing, distribution, and transportation were among the industry practices that led to these issues. Due to environmental problems such as air emissions, water pollution, ecological destruction, and water disposal, it is a difficult challenge for businesses to address.

The manufacturing sector, specifically run by SMEs, is one of the significant contributors to the degradation of environmental health from this viewpoint. Interestingly, environmental management values and standards provide practical tools to offer substantial improvements to the performance of the environment in organizations. However, the focus is narrowed to the development and documentation of environmental policies and procedures. As a result, those policies and procedures improve the environment's efficiency from inputs to outputs and source to end-users. This paper concentrates on SMEs and looking at their existing eco-business model as a guideline to operate their businesses in the industries involved in green business practices concerning the environment. These environmental issues appeared to be a significant concern for companies and public organizations. In essence, competent policies are required to alleviate these profound problems. A well-designed policy must come with relevant understanding and support from business owners, mainly to preserve the sustainability of the environment. Here, studies and initiatives are needed to improve the growth of business practices and their sustainability.

## Acknowledgements

This research received funding and assistance from the Institute of Scientific Management & Innovation, Universiti Teknologi MARA (UiTM) for the awarded research grant with the project code: 600-IRMI 5/3/LESTARI (031/2018). The writers would like to express their gratitude to all respondents who took part in the survey considering the pandemic (Covid 19). Finally, the authors would like to express their appreciation to the Faculty of Business and Management at UiTM for their assistance in completing this study.

## Paper Contribution to Related Field of Study

Regulations, customer pressure, and social responsibility appear to have a significant relationship to expected business benefits, as found in this study. Companies dealing with manufacturing are facing demands from the consumers in having eco-initiatives to maintain good environmental sustainability. It is prevalent to take immediate actions, although preserving the environment while performing business is challenging and of debate. It is expected from the findings that more companies will implement green practices in their daily business operations.

## References

- Abdul Aziz, N. A., Ong, T. S., Foong, S. Y., Senik, R., & Attan, H. (2018). Green Initiatives Adoption and Environmental Performance of Public Listed Companies in Malaysia. *Sustainability* 2018, 10(6), 2003; <https://doi.org/10.3390/su10062003>
- Anbumozhi, V., Kanda, Y. (2005). Greening the production and supply chain in Asia: Is there a role for voluntary initiatives. IGES Kansai Research Centre KRC.
- Andersen M. M. (2010). Eco-innovation toward a taxonomy and a theory. Paper for the DRUID conference, June 18-20: Copenhagen.
- Bansal, P., & Roth, K. (2000). Why companies go green: A model of ecological responsiveness. *Academy of Management Journal*, 43(4), 717-736.
- Behera, S. K., Kim, J-H., Lee, S-Y., Suh, S., & Park, H-S. (2012). Evolution of 'designed' industrial symbiosis networks in the Ulsan eco-industrial park: 'research and development into business' as the enabling framework. *Journal of Cleaner Production*, 29-30, 103-112.
- Christensen, H. B., Hail, L., Leuz, C. (2019). Adoption of CSR and Sustainability Reporting Standards: Economic Analysis and Review. *European Corporate Governance Institute - Finance Working Paper No. 623/2019*. <https://ssrn.com/abstract=3427748> or <https://dx.doi.org/10.2139/ssrn.3427748>
- Crane, A., McWilliams, A., Matten, D., Moon, J., & Siegel, D. (Eds.). (2008). *The Oxford University Handbook of CSR*. Oxford, UK: Oxford University Press.
- De Bruijn, & Lulofs, K. R. D. (2001). Promoting environmental management in Dutch SMEs: policy implementation networks.
- De Bruijn, T., & Lulofs, K. R. (2001). Promoting environmental management in Dutch SMEs: policy implementation networks.
- De Marchi, V. (2012). Environmental innovation and R&D cooperation: Empirical evidence from Spanish manufacturing firms. *Research Policy*, 41(3), 614-623.
- Eltayeb, T. K., Zailani, S., & Ramayah, T. (2011). Green supply chain initiatives among certified companies in Malaysia and environmental sustainability: Investigating the outcomes. *Resources, Conservation and Recycling*, 55, 495-506.

- European Commission. (2013). Communication from The Commission To The European Parliament And The Council. European Commission, available at: <https://eur-lex.europa.eu/legal-content/EN/TXT/PDF/?uri=CELEX:52013DC0833&from=EN> (accessed: June 15, 2019)
- Fernando, Y., Wah, W. X., & Shahrudin, M. S. (2016). Does a firm's innovation category matter in practising eco-innovation? Evidence from the lens of Malaysia companies practising green technology. *Journal of Manufacturing Technology Management*, 27(2), 208-233.
- Fussler, C. and James, P. (1996) *Eco-innovation: A Breakthrough Discipline for Innovation and Sustainability* (Pitman Publishing).
- Hair, J. F., Ringle, C. M., & Sarstedt, M. (2011). PLS-SEM: Indeed a silver bullet. *Journal of Marketing Theory and Practice*, 19(2), 139–151
- Halila, F., & Rundquist, J. (2011). The development and market success of eco-innovations. *European Journal of Innovation Management*. Kondoh, Shinsuke, et al. "Analysis of Key Success Factors for Eco-Business Through Case Studies in Japan." *IJAT* 6.3 (2012): 252-263.
- Koirala, S. (2018). *SMEs: Key Drivers of Green and Inclusive Growth*. OECD, Paris. Retrieved from [https://www.oecd.org/greengrowth/GGSD\\_2018\\_SME%20Issue%20Paper\\_WEB.pdf](https://www.oecd.org/greengrowth/GGSD_2018_SME%20Issue%20Paper_WEB.pdf)
- Kondoh, S., Kurakawa, K., Kato, S., Umeda, Y., & Takata, S. (2012). Analysis of Key Success Factors for Eco-Business Through Case Studies in Japan. *IJAT*, 6(3), 252-263.
- Lin, C. Y., Shah Alam, S., Ho, Y. H., Al-Shaikh, M. E., & Sultan, P. (2020). Adoption of Green Supply Chain Management among SMEs in Malaysia. *Sustainability* 2020, 12(16), 6454; <https://doi.org/10.3390/su12166454>
- Lehtoranta, S., Nissinen, A., Mattila, T., & Melanen, M. (2011). Industrial symbiosis and the policy instruments of sustainable consumption and production. *Journal of Cleaner Production*, 19, 1865-1875.
- MacArthur, E. (2015). Delivering the Circular Economy—A Toolkit for Policymakers. *Publication of Ellen MacArthur Foundation*. European Commission. *Flash Eurobarometer 381—SMEs, Resource Efficiency and Green Markets*;
- Moorthy, M. Krishna, et al. (2012), "Drivers for Malaysian SMEs to go green." *International Journal of Academic Research in Business and Social Sciences* 2.9: 74.
- Porter, M. E., & Kramer, M. R. (2006). The link between competitive advantage and corporate social responsibility. *Harvard business review*, 84(12), 78-92.
- Ramli, N. A., & Munisamy, S. (2013). Technical Efficiency and Eco-Efficiency in Manufacturing Industry: A Non-Parametric Frontier Approach. *Proceedings of 3rd Asia-Pacific Business Research Conference 25 - 26 February 2013, Kuala Lumpur, Malaysia*, ISBN: 978-1-922069-19-1.
- Ravi, V., Shankar, R., & Tiwari, M. K. (2005). Analyzing alternatives in reverse logistics for end-of-life computers: ANP and balanced scorecard approach. *Computers & Industrial Engineering* 48 (2005), 327–356.
- Rizos, V., Behrens, A., Van Der Gaast, W., Hofman, E., Ioannou, A., Kafyke, T., & Topi, C. (2016). Implementation of circular economy business models by small and medium-sized enterprises (SMEs): Barriers and Enablers. *Sustainability*, 8 (11).
- Savita, K.S., Dominic, P.D.D., & Ramayah, T. (2012). Eco-design strategy among ISO 14001 certified manufacturing firms in Malaysia: Green drivers and its relationship to performance outcomes. *International Conference on Computer & Information Science (ICIS)*.
- Sekaran, U. (2000). *Research methods for business: A skill-building approach* (3<sup>rd</sup>ed). New York: John Wiley & Sons Inc.
- SME Corp Malaysia (SMECORP). (2014). *Guideline for New SME Definition*. SMECORP, [https://www.smecorp.gov.my/images/pdf/Guideline\\_for\\_New\\_SME\\_Definition\\_7Jan2014.pdf](https://www.smecorp.gov.my/images/pdf/Guideline_for_New_SME_Definition_7Jan2014.pdf) (accessed: December 16, 2020)
- Webster, S., & Mitra, S. (2007). Competitive strategy in remanufacturing and the impact of take-back laws. *Journal of Operations Management*, 25(6). 1123-1140.
- Wooi, G. C., & Zailani, S. (2010). Green supply chain initiatives: investigation on the barriers in the context of SMEs in Malaysia. *International Business Management*, 4(1), 20-27.
- Worthington, Ian, and Dean Patton (2005). "Strategic Intent in the Management of the Green Environment Within SMEs: An Analysis of the UK Screen-printing Sector 197." *Long Range Planning* 38: 119.
- Yahya, N., Nair, S. R., & Piaralal, S. K. (2014). Green practices adoption framework for small and medium sized logistics firms in Malaysia. *Sains Humanika*, 2(3).
- baheYusoff, W. F. W., & Adamu, M. S. (2016). The relationship between corporate social responsibility and financial performance: Evidence from Malaysia. *International Business Management*, 10(4), 345-351.
- Zailani, S., Govindan, K., Iranmanesh, M., Shahrudin, M. R., Chong, Y. S. (2015). Green innovation adoption in automotive supply chain: The Malaysian case. *J, Clean Prod*, 108, 115-1122.