



## **International Virtual Colloquium on Multi-disciplinary Research Impact (2<sup>nd</sup> Series)**

Organised by Research Nexus UiTM (ReNeU)  
Office of Deputy Vice Chancellor (Research and Innovation)  
Universiti Teknologi MARA 40450 Shah Alam, Malaysia, 15 Oct 2021



# **Empirical Identification of Perceptual Design Criteria for Ablution Concept**

**Diana Mohamed Raif <sup>1</sup>, Rusmadiyah Anwar <sup>2</sup>, Mohd Khairi Baharom <sup>3</sup>**

<sup>1,2</sup> National Design Centre, College of Creative Arts, Universiti Teknologi MARA Shah Alam, 40450 Shah Alam, Selangor, Malaysia

<sup>3</sup> College of Creative Arts, Universiti Teknologi MARA Cawangan Perak, 32610 Seri Iskandar, Perak, Malaysia

[diana0156@uitm.edu.my](mailto:diana0156@uitm.edu.my), [rusma935@uitm.edu.my](mailto:rusma935@uitm.edu.my), [mohdk135@uitm.edu.my](mailto:mohdk135@uitm.edu.my)  
Tel: +60 13 890 8298

### **Abstract**

This paper was initiated based on the conceptual framework of Ablution Function Mean Analysis relating to a phenomenon that impacts designer perception in developing new product development for religious-based design. Empirical observation of user-designer exploring the convergent process of abluion design development was set up. The abluion performed, the perceptions verbalized, and the different design principles targeted were analyzed from a qualitative and a quantitative point of view. This study's data were first measured to obtain an appreciation of Muslims performing abluion behaviour. The study focused on the product gestalt, recognising the design act of divergent and convergent transpires in a real context, and identifying the spontaneous control reflection that influences the resulting product perception.

Keywords: Design gestalt; abluion; design thinking.

eISSN: 2398-4287 © 2022. The Authors. Published for AMER ABRA cE-Bs by e-International Publishing House, Ltd., UK. This is an open access article under the CC BYNC-ND license (<http://creativecommons.org/licenses/by-nc-nd/4.0/>). Peer-review under responsibility of AMER (Association of Malaysian Environment-Behaviour Researchers), ABRA (Association of Behavioural Researchers on Asians) and cE-Bs (Centre for Environment-Behaviour Studies), Faculty of Architecture, Planning & Surveying, Universiti Teknologi MARA, Malaysia.  
DOI: <https://doi.org/10.21834/ebpj.v7i1SI7.3783>

### **1.0 Introduction**

Design thinking is a contemplative longing to change the world using aesthetics, ethics, and knowledge (Nelson & Stolterman, 2003). Professional designers have frequently explained that novice designers require a sufficiently broad design solution to perform adequately. Because the thinking behind design isn't completely understood, designers struggle to explain how they make the connections that lead to them being the outcome and why those decisions are rational. Every designer uses their own imagination from a concept in their head, which appears to be a significant feature of the design process. Form development from ideas can be transformed into a design drawing proposal in current design practice by using appropriate sketching techniques. According to Quinn (2007), sketching and combining Marquette making can influence idea generation. According to Anwar et al. (2015), the current literature on design cognition does not adequately clarify which abstract aspects novice designers consider or how they connect intentions with their physical condition as the driving force behind producing, selecting, and developing ideas. Although it is commonly assumed that these novice designers will gain plan learning through ample exposure to design investigation in many displays, this recommendation is invalidated.

### **2.0 Ablution Design: An Overview**

Dr Ahmed Mokhtar (2005), in Design Guidelines for Ablution Spaces in Mosques and Islamic Praying Facilities, discusses the imperative background to designing a good abluion space. It is intended to be read by designers, government officials, and building owners to recognize what should be the minimum requirements to acquire an acceptable design for abluion spaces. He also explains the process of abluion to help designers understand the function. In addition, different locations of abluion space to praying space consist of a

eISSN: 2398-4287 © 2022. The Authors. Published for AMER ABRA cE-Bs by e-International Publishing House, Ltd., UK. This is an open access article under the CC BYNC-ND license (<http://creativecommons.org/licenses/by-nc-nd/4.0/>). Peer-review under responsibility of AMER (Association of Malaysian Environment-Behaviour Researchers), ABRA (Association of Behavioural Researchers on Asians) and cE-Bs (Centre for Environment-Behaviour Studies), Faculty of Architecture, Planning & Surveying, Universiti Teknologi MARA, Malaysia.  
DOI: [https://doi.org/10.21834/ebpj.v7i1SI7%20\(Special%20Issue\).3783](https://doi.org/10.21834/ebpj.v7i1SI7%20(Special%20Issue).3783)

discussion of the advantages and disadvantages of each possibility. This book covers the design of ablution units. It identifies the common types of these units and recommends design dimensions for each type (See figure 1). He said there are some well-designed ablution spaces. However, there are many more badly designed ones. The bad designs cause discomfort in using the space and can constitute a safety hazard. He also said that designers usually ignore the supporting spaces for the mosque. These supporting spaces can be required, such as the ablution spaces. Unfortunately, there is no design that designers provide users with safe and comfortable ablution spaces. In the process of obtaining information about the performing wudhu' of Muslims in Malaysia and how to improve the design of the ablution tub, this study prepared two different research foam. This is a process whereby data is obtained from as many different sources.

In the process of completing this study, two phases were conducted by using qualitative data: Observation of the method and rules of performing wudhu' and a questionnaire with Muslims who perform wudhu' at a mosque in Klang valley—analyzing and testing out the method of performing wudhu' and working pre-prototype with Muslim who is performing wudhu'. In conjunction, this study would like to highlight the syntactic structure of ablution design, creating a strong product gestalt to be identified as a standard design format, considering practical and environmental needs. For example, in sanitary ware design, we can easily recognize toilet bowl, sink, urinal, or bathtub as a strong sketch format. Any designer who wants to propose a new design for both toilet bowl, sink, urinal, or bathtub will follow the design principle that has been established. It is a huge possibility if this prototype research is to be developed since the syntactic structure of ablution can introduce the standard design format. On the other hand, a new sub-sanitary ware product will be introduced for the ceramic industries.





	Model 1	Model 2	Model 3	Model 4
Ablution Design				
Features	Seats, shelf	shelf	shelf	shelf

Fig. 1: Type of ablution design  
(Source: Mokhtar (2005))

## 2.1 Ablution

According to Sa'eed 'Ali Wahf al-Qahtani (1999), Taharah (cleanliness and purity) is half of the faith. A Muslim must be clean for offering prayer and reciting the Quran by way of wudu' (ablution, ghusl) or tayammum (dry ablution). Cleanliness encompasses both physical and spiritual aspects. Physical impurities can be removed by clean and pure water or dry cleaning through earth or stone and the beginning step for spiritual cleanliness. Purification in Islam is included in the worship because all worship in Islam requires purity and leads to holiness. Therefore, Allah obliges the wudu 'and purifies so that Allah servants are free from all filth and dirt during worship for Him (Ibnu Muhammad El-Fandahani, 2006).

Ablution is an action with several sequences that Muslims must perform before praying. This procedure can be performed at any time, inquiring for the person to be in this state till the stop of the prayer or to greater prayers. The ablution region is required earlier than any prayer as some moves can terminate this state, such as sleeping, journeying the lavatory, passing wind, or turning unconscious (Mokhtar, 2005). Ablution derives from the Arabic word 'wudu', which means cleanliness and brightness, apart from physical and spiritual actions. wudu must be ensured as a ritual cleansing and purification of the body, in which a few steps have to be performed to gain the state of ablution (Johari, Anwar, Hassan, & Kamaruzaman, 2013).

Rahim (2005) mentioned that wudu, or ablution is one of the Islamic teachings concerning cleanliness, which must be carried out before performing prayer. Moreover, ablution involves several steps that must be adequately performed to ensure the legibility of the prayer. This begins with cleaning several parts of the body with clean water, first rinsing the palms, rinsing the mouth, washing the nose, washing the face, washing each arm, wiping the hair, rubbing the ears with wet hands, and finally, washing the feet up to the ankles (Hamid, Wahab, Alias, & Rahmat, 2015). Sometimes, a full-body shower must be taken before the ablation procedure. If one has to stay for a prolonged period of time, showering facilities can also be required to be connected to the ablution space. The niyyah (motive) is the fundamental principle before the ablution, and after that, several movements have to be completed to be ready for the prayer. It is a disciplinary action that helps one to remain hygienically clean in private or public spaces.

## 2.2 Proposed concept

The use of the ablution space is one of the needs of the Muslims to perform the ritual. It is also part of the space that should be considered a place of public utility with its own characteristics. There is no source that explains the features of formal education. Then the construction of reliable ablution space is performed by architects or designers by experience itself. According to Mansoor Ahmad (2003), the only type of building that is not in the Time-Saver Standards and Architectural Graphic Standards is a mosque and madrasa. After 1400 years of practice, not a single Muslim is able to resolve the issue of the mosque on the function and cleanliness (ablution place and so on) to the function. We may achieve an identity if we do not wait for a later time.

From the above statement, a case study by Johari (2013) has discovered a relation between water, human gesture, and human behaviour turns into the major and fundamental factor in designing the products. It has provided a more similar approach to designing

ablution tubs based on an ergonomic perspective. In order to construct a relational theory for design, Jonathan (2009) stated that they need a concept that will enable them to address the interactions between designers, artifacts, and users. The product synthesis takes as its starting point the two outputs from the problem analysis, namely the formulation of the desired function and the list of preferred properties (Tjalve, 1979).

An ablution facility is very important and should have in every mosque because it is a needed requirement before prayers. The importance of wudhu' facilities should be given emphasis so that users can perform more properly on wudhu'. Based on observation, this study found that the good ablution facilities must have a characteristic of hygienically, conveniently and efficient because this matter involves safety and hygiene when users perform wudhu'. In addition, the design of the ablution space must be suitable for the human size and movement while performing wudhu' to give more ease and comfortable to users when performing wudhu'.

Refers to the research of Anwar et al. (2016), when it involves the concept development of Product Architecture, which determine by product change, product variety, component standardization, product performance, and product development management, the process of divergent convergent should be used strategically to develop an idea inspiring complete form of ablution concept (See figure 2). From this analysis, the design structure (syntactic) formed is important to structure explicitly the ablution to occupy the need to perform the principles (face, both hands, forehead, and both feet). Moreover, this study found how important it gives emphasis to the design of ablution places. Without any innovation, the sooner or later the importance of Muslims needed will be lost. This is also the factor this study was conducted and produce an innovation of ablution tub that can give more easiest for Muslims needed on ablution facility.

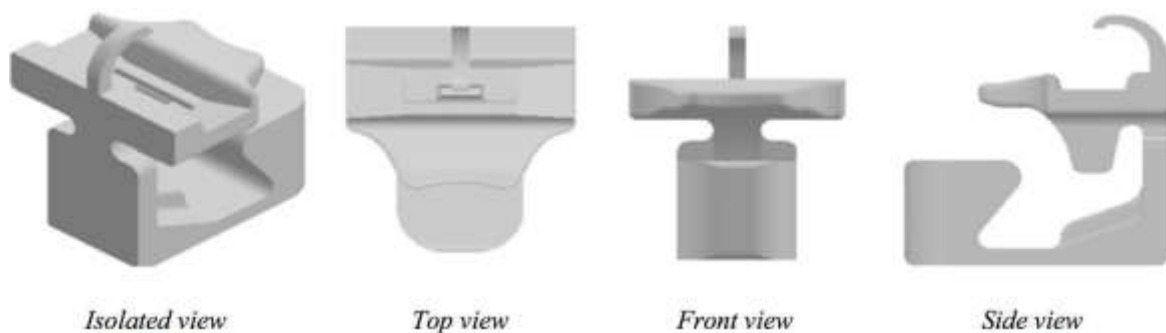

Fig. 2: Propose concept adapted from Anwar et al. (2016)  
(Source: Anwar et al. (2016))

### 3.0 The Research Design

For this preliminary design study, we apply Design Protocol Analysis (DPA) adapted from Anwar (2016) as the strategy, the plan, and the structure of conducting this research project. DPA is known as one method to be considered as a theory of correct scientific decisions of art or creative practices (Anwar et al., 2015). This is common sense and clear thinking necessary for the management of the entire research endeavour. Hence to achieve the best control and validity of the study. The experimental design plan through Ablution Function Mean Analysis (Anwar et al., 2015) is to meet specified objectives in creating an ablution product as a whole. The DPA is put into practice to ensure that the right acceptable empirical design investigation as clearly and efficiently as possible (Abidin, 2012).

The fundamental idea underlying this model is that in an integrated design process, the involved stakeholders shall run through a progression of phases of divergent and convergent thinking. Every phase of divergence is a phase of idea generation and out-of-the-box thinking related to ablution tub design and arranged previously. Experts from different domains with Industrial Ceramic design backgrounds and experience cooperate in this design protocol analysis, where the principal function is to open up their minds to be able to get out of their boxes in ablution tub design contexts. The numerous ideas have to be consolidated and evaluated in the subsequent convergence phase whose principal objective is to decide how to proceed with every single idea generated during the past phase.

In order to allow us getting strong conclusions about cause and effect by directly control the independent variable in a natural situation, Perceptual Product Experience (PPE) framework used as a guide to understand, map, organize and analyze possible user experiences, by means of the sensory, cognitive and affective mode of user-product interactions. The PPE framework ( Figure 3) focuses on how we experience products with all senses, how we process and categorise stimuli and make sense of things; and how we feel and think of things when we experience products (Warell, 2008).



Fig. 3: Perceptual Product Experience  
(Source: Warell (2008))

For the research explorations, it begins with identifying the problem through observation; collecting the data through ergonomic practices while performing the principle activity required (experimental design as an approach to investigate the ergonomics level achieved by a human through performing wudhu'); evaluating and synthesizing the data through artifact analysis and finally provide results that are reliable and valid through user perceptual. This research study ultimately focuses on issues related to the design tub for performing wudhu' (ablution) of Muslims in Malaysia.

#### 4.0 Ablution Gestalt as Divergent and Convergent Design Task

In this section, the researcher will clarify the process of design development from product selection and to the final model design. The design and development of the project are proposed based on the result analysis that was found from the first phase of data collection, which is the interview and the observation. The researcher identifies design criteria from data analysis also as a guide in the process of the design development of the project proposed.

This project is focused on developing the prototype of an ablution tub for users. It's undoubtedly contributed to the wudhu facility design by concerning the human factor engineering aspect (ergonomic). Principle-solution requires design-inspired approaches and the final design structure of ablution design endows the theory of formgiving design (Figure 4) in which, the visual elements form is part of the attributes of form that create tone and texture, imparting visual interest and meaning. Their importance becomes evident through their use in generating images and form(s) that are both two-dimensional (2D) and three-dimensional (3D). Within agreement about the understanding of the use of basic entities of visual elements such as point, line, plane or surface, and volume, as well as the organization rules and principles for putting together the composition or structure (Akner Koler, 2000). This element then will become a guide for generating the ablution tub form.

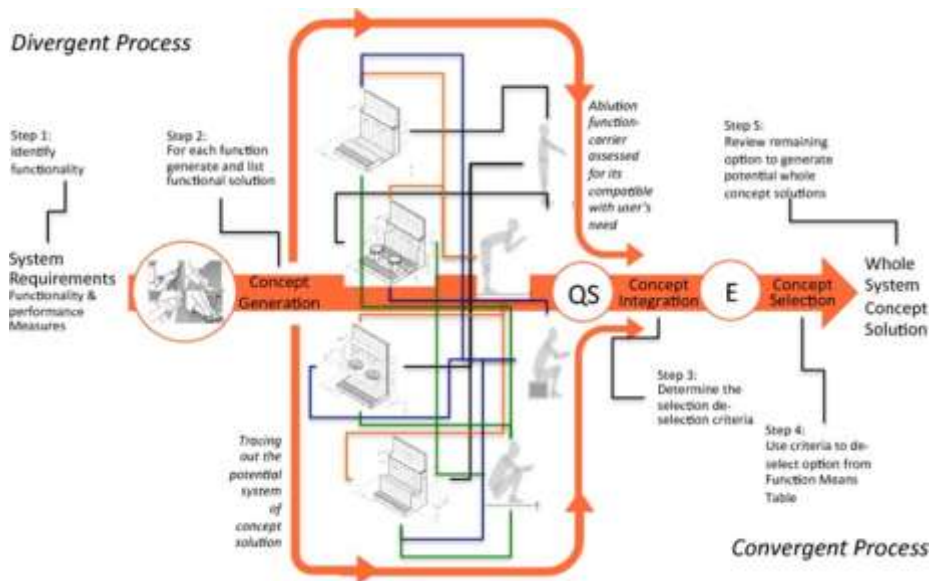

Fig. 4: Ablution Function Mean Analysis (Source: Anwar (2015))

#### 4.1 Problems Identifications 1: Design Gestalt Issues

Based on the first observation of ablution place (Figure 5), the researcher found that cleanliness, safety, and neatness are not concerned in ablution place and space, and this statement is also support from the interview sessions with imams and safety officers. The researcher also found that human body posture while performing wudhu' have to be considered to ensure the attribute of consumers on comfort body stability while performing wudhu'. From this problem, the researcher realizes that wudhu' facilities have to be improvised in accordance with consumer safety and also can give more comfort to consumers to use it. Besides that, the improvised design for this ablution space must be consistent and compatible with the criteria that involve all components in improving comfortable to users, which is in cleanliness, safety, and neatness.



Fig. 5: Existing design for ablution

According to Gestalt psychology, every perceptual image is more than the sum of its parts; it has a gestalt that acts as a patterning force that holds the parts together. Thus, the phenomenon is created in a visual product form by forms entities belonging to the organ domain, resulting in syntactic functionality (Warell, 2001). The observation-on-observation task is to trace the gestalt effect through aesthetic organs based on observations made during the design process. According to Warell (2001), these aesthetic organs produce effects that are subjectively perceived by observers as well as effects that serve a communicative (syntactic) function. In the meta-analysis, these work elements (functional fulfillment) and form entity (functional surface) are used to identify organ domains (Anwar, 2015). Attempts to understand the reasoning capabilities of designers while generating whole forms. When selecting participants, a general understanding of the arrangement of the parts as a whole (ablation gestalt) is taken into account. Because the DPA result shows the organization's element on all visible surfaces, it has responded to gestalt phenomenology and reveals the approach used by designers in constructing the design structure. According to Schreuder (2014), there is a distinct possibility of combining emergence, reification, multistability, and invariance to form a unified mechanism on a different level. In addition to gestalt rules, Klöcker (1980) agrees on a 'secondary gestalt phenomenon,' which includes optical illusions such as 'impossible figures,' the tensioned line or the dynamic curve, and ambiguous figures, which allow for multiple interpretations in viewing.

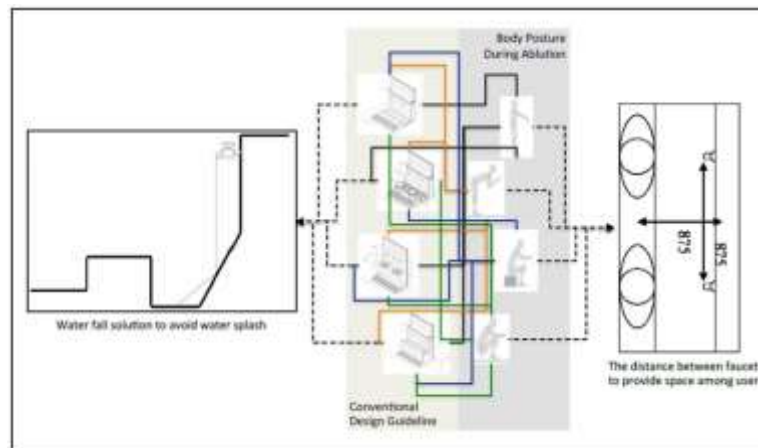

Fig. 6: Ablution Design Gestalt  
(Source: Anwar et al., 2017)

In this regard, the diagram in Figure 6 depicts how the process of determining a design activity in this study to learn about the design thinking procedure toward gestalt development in the ablation design process. Furthermore, as a design specification, the researcher identifies the relationship of three elements: concepts, materials, and technical. The implementation of three specifications is based on Nilsson's research (1998). He addressed that producing product design, particularly in the specification, it has to include the process of material and technical, which is supported by Anwar's research (2015). This research prioritizes design thinking and design process through gestalt development as a method for product design creation in a critical situation. In this context, it is possible to consider how groups of designers with varying levels of design thinking enhance and implement gestalt factors in the creative development process.

#### 4.2 Problems Identifications 2: Human Posture Issues

Based on the Figure 7 below, the researcher noted that most the ablation spaces do not put importance on cleanliness, safety and neatness. Moreover, it is also not concerned about comfort features for users. According to Agus Mansur and Didi Tri Wicaksono (2008), Designing and providing wudhu' places are expected to become significant notice for the managers of worship places regarding the importance of the places. They also state that, in the wudhu' facility design, the anthropometric approach will be employed as the ergonomic technique. Anthropometric dimension measurement is purposed for fitting of design between the wudhu' facility and the users. In addition, the researcher also has done with an observation on the human posture when performing wudhu'. This method is made to ensure the characteristic of consumers on comfort body stability while performing wudhu'.



Fig. 7: Human body posture while performing wudhu'

The prototype fabrication will be based on the collection of conceptual ablation design documented from previous research (Johari et al., 2012; Anwar et al., 2014; Anwar et al., 2016) which will be constructed, scan structural design, combine with heritage motif and elements established in local craft industry through 3D industrial design consideration to produce competitive 3Dimensional ablation design visual for potential sub-sanitaryware product's segment. These new niche heritage design combinations will strictly analyze as 'Ablution Function Mean Analysis' variance to perform new symbolic meaning with strong commercial value direction and impetus to qualify as a sanitary ware product design being the benchmark.

### 5.0 Product Gestalt Development Strategy: A Pilot Test through Design Protocol Analysis

This design study's design task is to propose an ablation tub design (See figure 8). Respondents have twenty-five minutes to study and sketch the idea solution onto drawing paper, which has three abstraction levels: abstract, semi-concrete, and concrete (Anwar, 2016). The experiment environment includes three video cameras (from various angles), five distinct influenced image panels, a prototype of an ablation tub as a sample, a computer for web searching, drawing paper, three different colours of pens, a whiteboard, and a clock timer (Anwar et al., 2016). The respondent's actions during the design activity will be recorded and analyzed in order to characterize the flow of design data in order to facilitate its capture, classification, and retrieval to aid in the ablation tub design process. Aside from analyzing how they solve design issues, these designers are experts in materials, concepts, or technical in the field of ceramics, as evidenced by the various reference materials provided based on different domains with Industrial Ceramic design backgrounds and experience. This refers to several ceramic designers who were investigated in their case study and mentioned to be consistent with what Nilsson (1998) claimed, in producing product design, especially in the specification, it has to comprise the material and technical process, on the other hand, it's more of a concept, material, and technical research approach (Anwar, 2015). This empirical study is investigating their intuitive development process, identifying design elements, performing product structure, and clarifying function mean analysis in form-giving (form creation) (Abidin et al., 2008; Anwar et al., 2015).

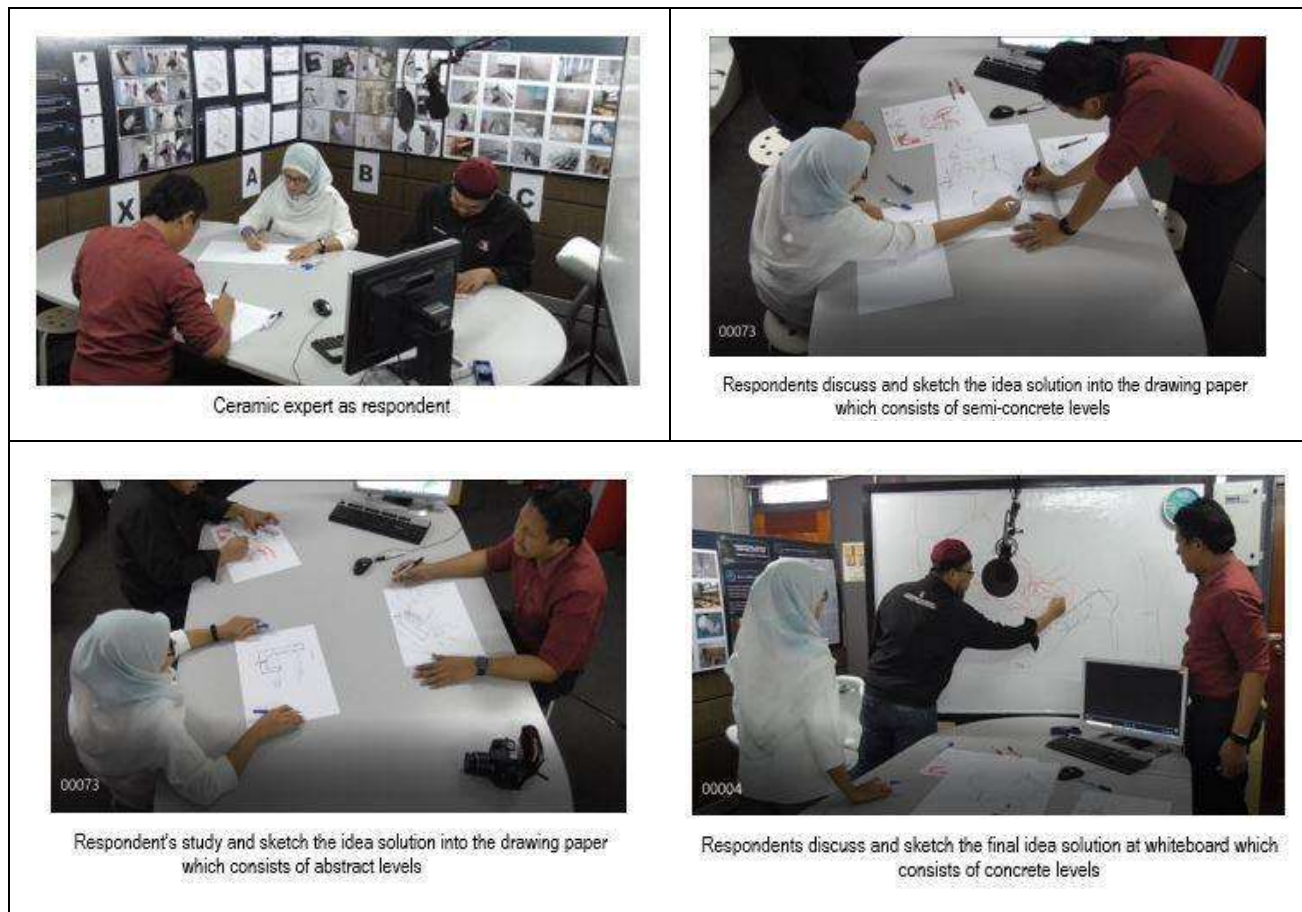

Fig. 8: Design task during DPA experiment

### 6.0 Conclusion and Recommendation

This research aims to evaluate product form design from the perspective of Product Gestalt theory. A contextual study conducted to demonstrate the viability of this proposed model. Furthermore, this model can be linked to related design fields as well as product design to product form design. A product form design is an imaginative procedure that includes complex visual discernment for the industry. It is important to build an effective decision support system for designers to manage issues concerning consumers' psychological preferences

toward product forms. Because Product Gestalt theory provides an important perspective on visual perception, it is appropriate to apply these standards in evaluating the quality of product form design. At the same time, this study may impact developing a descriptive model of Ceramic Design Protocol using Gestalt Principles in Semantic Design Representation and critical ceramic design situations.

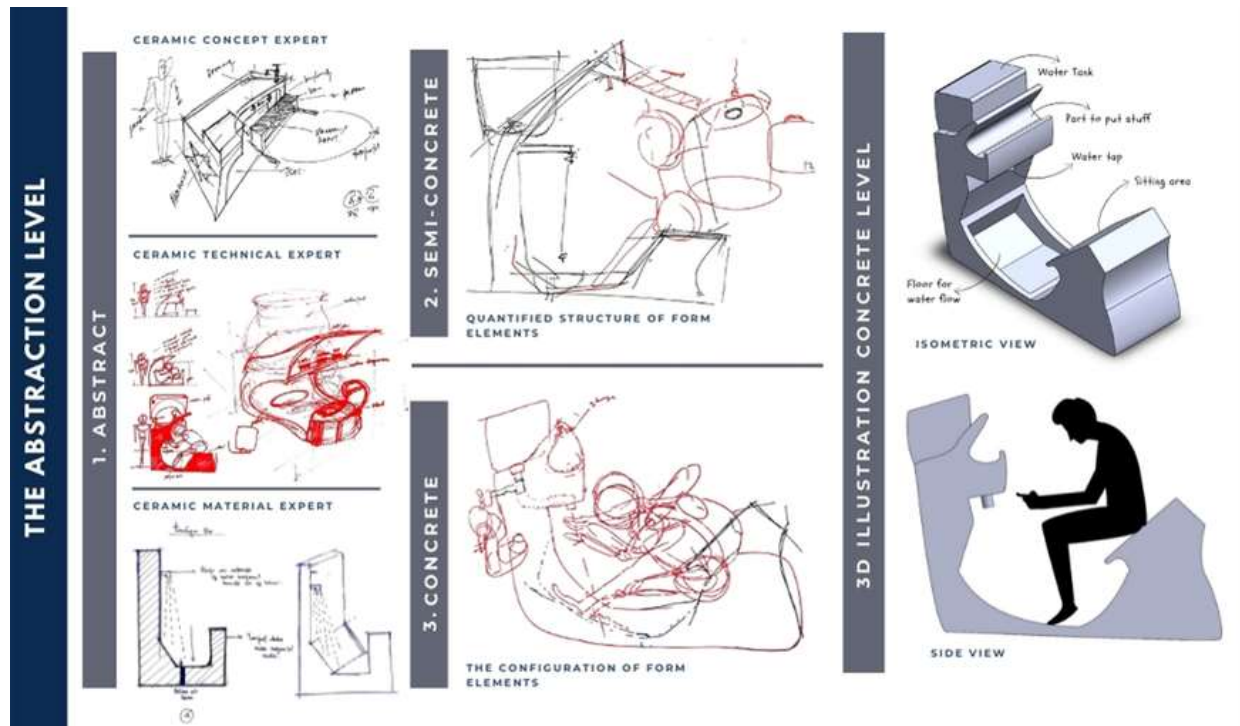

Fig. 9: The abstraction level of design experiment during DPA

The DPA experiment demonstrates that designers can derive design and divide it into three levels of abstraction: abstract, semi-concrete, and concrete as refer to Figure 9. Designers choose and decide the specification of design aspects that will satisfy the needs of ablation tub design on the first level of design development based on their respective expertise and understanding in ceramic fields. Structure the design brief by stating the direction of the design task in an apparent divergent phase, which the designer acknowledges to present an excellent level of convergent (Anwar et al., 2016). According to the abstract level, the designer has "assembled" all form components into one structure, with the inclusion of three-element specifications that are a concept, material, or technical. As the design process progresses to the next level (semi-concrete), designers begin to discuss and combine their individual ideas at an abstract level, identifying the relationship of three elements as a design specification, which are concepts, materials, and technical, to determine the best consideration and most promising design structure for ablation practice. As the designers confidently configure the form element with the relation of ablation requirements, the design activity (concrete level) comes to an end. The designers determined a gestalt study during product development (R. Mono, 1997). The structure of the ablation design was well organized, arranged, and correlated with the ergonomic, technical, and practical ablation performance requirements.

## Acknowledgements

We would like to acknowledge The Ministry of Higher Education Malaysia and Universiti Teknologi MARA (UiTM) for financial support. This study was conducted in the National Design Centre, Faculty of Art & Design, UiTM. We would like to acknowledge the generous participation in the research. Fully appreciate to Malaysia Ministry of Higher Education for the financial support under FRGS grant with a Sponsorship Grant No. FRGS/1/2019/SSI04/UITM/03/1 and registered under UiTM Research Management Centre File No.600-IRMI/FRGS 5/3 (449/2019).

## References

- Abidin, S. Z., Sigurjonsson, J., Liem, A., & Keitsch, M. (2008). On the Role of Formgiving in Design. *International Conference On Engineering And Product Design Education*. (pp. 365-370). Barcelona: Design Society.
- Abidin, S. Z. (2012). *Practice-based design thinking for form development and detailing*. Trondheim: Norwegian University of Science and Technology.
- Abidin, S. Z., Bjelland, H. V., & Øritsland, T. A. (2008). The embodied mind in relation to thinking about form development. *Proceedings of NordDesign 2008 Conference* (pp. 265-274). Tallin: Design Society.

- Anwar, R. Abidin, S. Z. and Hassan, O. H. (2015). Function Means Analysis for Ablution Concept Solution. *The Turkish Online Journal of Educational Technology*, pp. 224–231
- Anwar, R. Abidin, S. Z. and Hassan, O. H. (2016). In-Vitro Design Protocol: Artificial Situation Strategy Uses to Comprehend Designers' Thought. *MATEC Web of Conferences*, 2016.
- Anwar R., Abidin S.Z., Hassan O.H. (2015) A Pattern in Formgiving Design: Giving Priority to a Principle Solution in Industrial Design Situation. In: Gen M., Kim K., Huang X., Hiroshi Y. (eds) *Industrial Engineering, Management Science and Applications 2015. Lecture Notes in Electrical Engineering*, vol 349. Springer, Berlin, Heidelberg. [https://doi.org/10.1007/978-3-662-47200-2\\_35](https://doi.org/10.1007/978-3-662-47200-2_35)
- Anwar, R. Abidin, S. Z. and Hassan, O. H. (2015). A practical guideline to quantifying qualitative analyses of design cognition. *The Turkish Online Journal of Educational Technology*. Special Issue 1 for IETC 2015.
- Anwar, R. Abidin, S. Z. and Hassan, O. H. (2015). Understanding methodological solution in design situation of novice designer. *International Conference on Interactive Collaborative Learning (ICL2015) Florence: Italy*. pp593-597. IEEE.
- Agus Mansur and Didi Tri Wicaksono (2008), "Ergonomic Design Of Wudhu Facility For Disables", Universitas Islam Indonesia, Yogyakarta.
- Akner-Koler, C. (2000). *Three-dimensional visual analysis*. Stockholm: Reproprint.
- Ahmed Mokhtar (2005), "Design Guidelines for Ablution Spaces in Mosques and Islamic Praying Facilities", The American University of Sharjah.
- Hamid A.B.A., Wahab M.H.A., Alias A., Rahmat N. (2015) Ablution Design: The Concepts and Design Criteria. In: Abidin S., Legino R., Noor H., Vermol V., Anwar R., Kamaruzaman M. (eds) *Proceedings of the 2nd International Colloquium of Art and Design Education Research (i-CADER 2015)*. Springer, Singapore. [https://doi.org/10.1007/978-981-10-0237-3\\_48](https://doi.org/10.1007/978-981-10-0237-3_48)
- Ibnu Muhammad El-Fandahani (2006), "Kaifiyat Bersuci", Crescent News (K.L) Sdn. Bhd.
- Johari, N. H., Anwar, R., Hassan, O. H. and Kamaruzaman, M. F. (2013). *Human Behaviours Influence Framework of the Ablution Tub Design*
- Klöcker, I. (1980). *Die Produkt-Form und menschliches Verhalten*. Hannover, Germany: Technische Universität Hannover.
- King, D. B., Wertheimer, M., Keller, H., & Crochietiere, K. (1994). *The legacy of Max Wertheimer and Gestalt psychology*.
- Lyons, A. (2001). *Gestalt Approaches to the Virtual Gesamtkunstwerk*.
- Nilsson, M. (1998). *Component Design: A theoretical study of form synthesis, material selection and process selection*, Linköping: Linköping University
- R. Mono. *Design for Product Understanding: The Aesthetics of Design from a Semiotic Approach*. Stockholm: Liber AB (1997).
- Sa'eed 'Ali Wahf al-Qahtani (1999), "The Purity of The Muslim". International Islamic Publishing House
- Tjalve, E. (1979). *Systemathic Design of Industrial Products*. Lyngby: Technical University of Denmark, Institute for Product Development
- Warell, A. (2008). *Modelling Perceptual Product Experience - Towards a Cohesive Framework of Presentation and Representation in Design*. Proceedings of the 6th International Conference on Design & Emotion. Hong Kong: Hong Kong Polytechnic University.
- Warell, A. (2001). *Design Syntactics: A Functional Approach to Visual Product Form*. Goteborg: Chalmers University of Technology.